

4

3

2

1

- 20 EA. SWT 850 PVC FILTERS, 4 BANKS OF 5 FILTERS EACH, 2 BANKS PER SKID
- 304SS FRAME
- 4" x 2" INFLUENT MANIFOLDS, INDIVIDUAL FILTER ISOLATION, 2" MANUAL PVC BUTTERFLY VALVES
- 4" x 2" EFFLUENT MANIFOLDS, INDIVIDUAL FILTER ISOLATION, PVC CHECK VALVES WITH FEP ENCAPSULATED 316SS SPRING
- 3" x 2" PURGE MANIFOLDS, INDIVIDUAL FILTER ISOLATION, 2" MANUAL PVC BUTTERFLY VALVES
- INDIVIDUAL MOTOR DISCONNECT SWITCH FOR EACH FILTER
- 13-5/8" CENTER SPACING BETWEEN FILTERS
- 16.25" SERVICE WALKWAY BETWEEN FILTER BAYS
- ~3800 LBS. (~1900/SKID) DRY WEIGHT

CONTROL PANEL:

- 460 VAC, 3Ø
- NEMA/ TYPE 4X OUTDOOR RATED ENCLOSURE
- 4000 BTU AIR CONDITIONER / 100 W HEATER
- INTERIOR LED LIGHTING
- MAPLE SYSTEMS 12.1" HMI W/ CLEAR POLYCARBONATE COVER & LATCH
- AB MICRO 850 PLC
- FUJI ELECTRIC 30 HP VFD CONTROLLING (20) 1 HP MOTORS
- 12 CH. PNEUMATIC SOLENOID MANIFOLD W/ 8 VALVES STANDARD, 4 AUX.
- DRY CONTACTS FOR REMOTE SIGNALING
- 5 PORT UN-MANAGED SWITCH W/ EXTERIOR CONNECTION AVAILABLE

REVISIONS				
REV.	DATE	DESCRIPTION	CHG BY	APP'D BY
U1	2/23/2022	INITIAL RELEASE	WBK	GJL

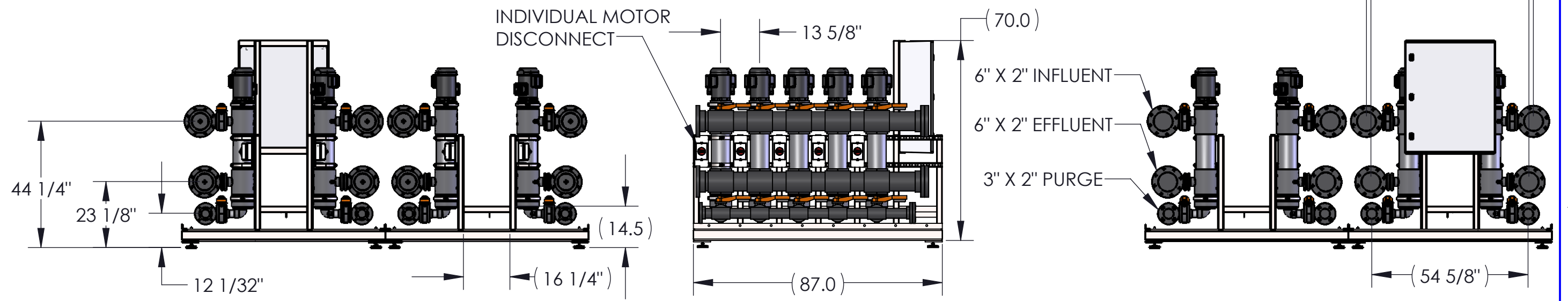
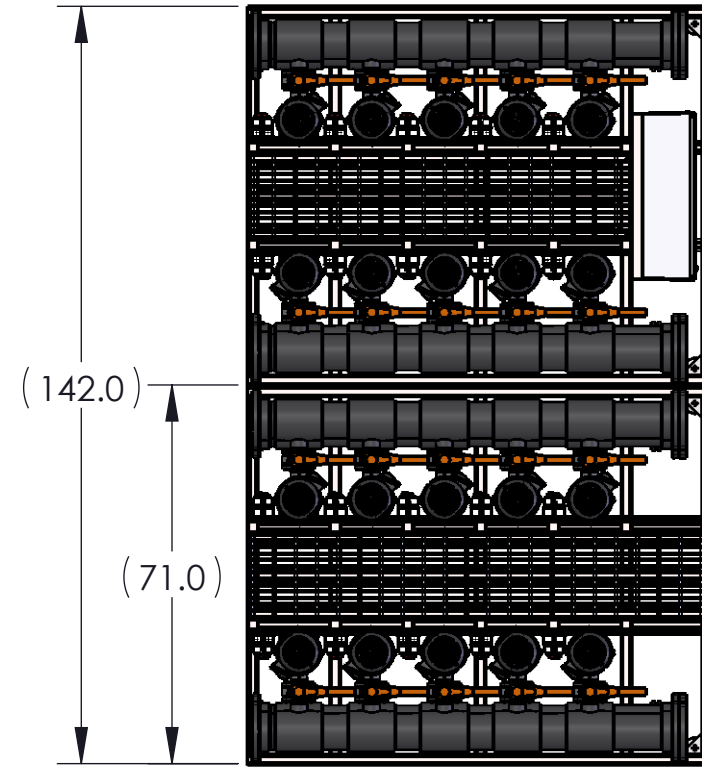
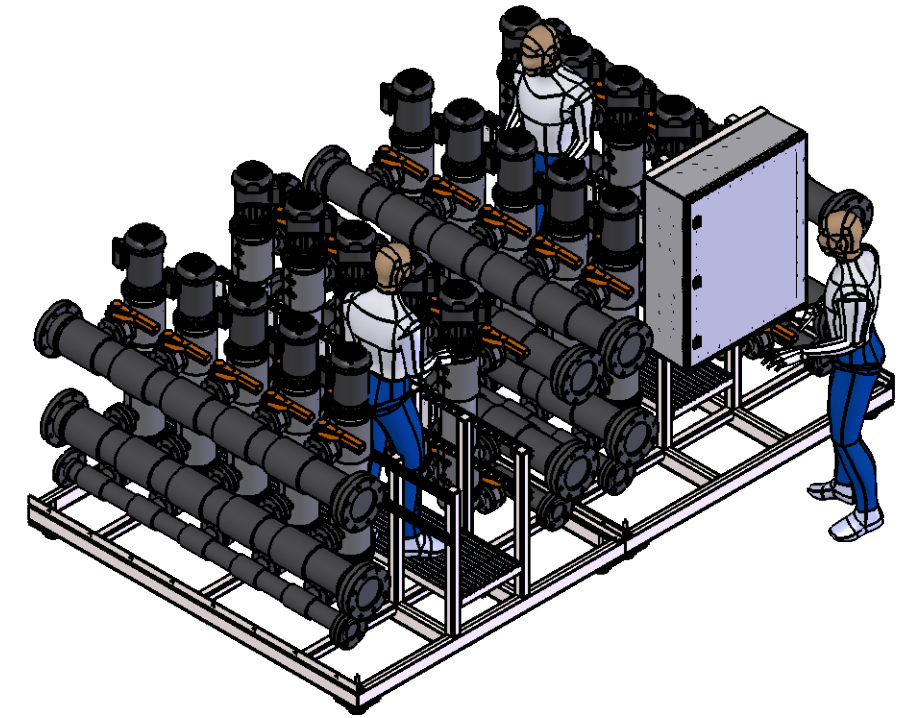

**SPIRAL WATER TECHNOLOGIES, INC.**



200 POND AVE  
MIDDLESEX, NJ 08846  
P: 732-629-7553

**PRODUCT SPECIFICATION DRAWING**

DRAWN BY WBK	2/23/2022	TITLE <b>SWT 850 PVC: 20 PACK ASSEMBLY LAYOUT</b>	REV <b>U1</b>
CHECKED BY MC	02-23-22		
APPROVED BY GJL	02-23-22		
SCALE 1:36		MODEL CONFIGURATION	SHEET 1 OF 1

4

3

2

1