

#### PRODUCT DESCRIPTION

The SWT850A-DPX is an automatic self-cleaning filter system designed to remove Ultra High and Variable Total Suspended Solids (TSS) from a fluid stream. Each filter unit contains a motor-driven, spiral-shaped brush that continuously cleans collected debris from inside the filter element. Solids collect at the end of the filter housing to be expelled through an automatic purge valve or a continuous concentrate stream. The system does not require high pressures to operate and performs at very low differential pressure. No backwash, cross flow or booster pumps required. The Purge chamber can be configured to dump solids directly to waste or for concentration of solids.

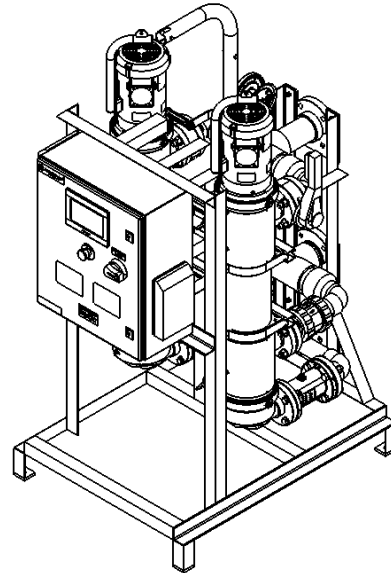

#### APPLICATIONS

Recycled Secondary Wastewater, Protection of Monitoring Equipment, Nozzle Protection, Bearing and Seal Protection, Wastewater, Recycled Water, TSS and BOD Reduction

#### TECHNICAL SPECIFICATION

Inlet:	3" #150 Flange
Filtrate Outlet:	3" #150 Flange
Purge Outlet:	2" #150 Flange
Max Flow:	150 gpm
Filtration Rating:	15 – 100 micron
Max TSS:	10,000+ ppm
Max Operating Press:	8.3 bar (120 psi) @70°F
Min Operating Press:	<0.1 bar (<1 psi)
Head Loss:	<0.1 bar (<1 psi)
Controls:	230/460VAC, 3-ph, 60Hz
Air Requirements:	30PSI above inlet pressure

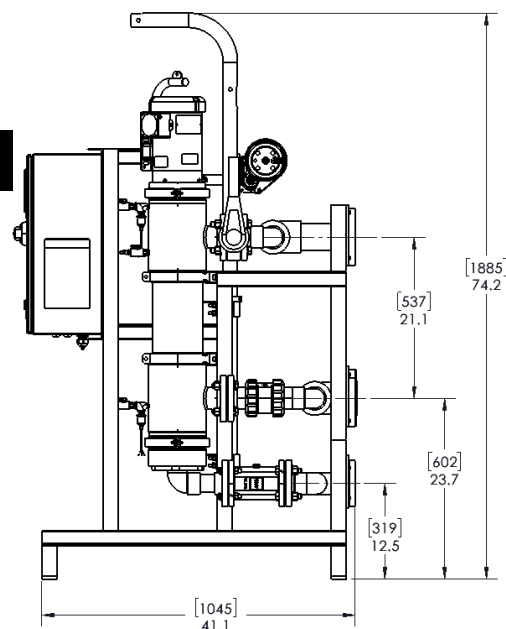

## MATERIALS OF CONSTRUCTION

Wetted Housing:	PVC, 2205 SS
Seals:	EPDM, Buna-N or Viton
Cleaning Brush:	Acetal, Nylon 6.12 & 316 SS
Filter Elements:	316L SS

## PERFORMANCE SPECIFICATION

The spiral shaped brush is designed to rotate continuously, so there is always less than 1 psi head loss across the filter screen. Flow through the filter unit is limited by hydraulic loading on the screen, which is driven primarily by liquid flow rate and viscosity. Flow rates listed below assume a viscosity of 1.0 cP and TSS up to 1000 mg/l. The unit is plumbed with a check valve on the filtered outlet with 2 psi cracking pressure. Operating pressure in the 1 to 10 psi range is optimal, though the unit is capable of 120 psi.

Liquid Recovery Rate: 99%  
Max Temperature: 120° F (49° C)

### Flow Rates for TSS up to 1000 ppm

Filter Screen	Nominal Filtration Rating (microns)	Max Flow Rate (gpm, [m <sup>3</sup> /hr])
SWT810-FE-BB	15	40 [9]
SWT810-FE-GG	20	60 [13.6]
SWT810-FE-YY	25	80 [18.2]
SWT810-FE-RR	50	150 [34.0]

Note: The higher the solids, the higher the perceived apparent viscosity. At TSS above 1000 ppm, lower flow rates are required to avoid fouling of the filter screen



Brush



Filter Screen