

INFLUENT AIR
RELEASE/
PRESSURE PORT

EFFLUENT AIR
RELEASE

EFFLUENT DRAIN/
PRESSURE PORT

3X 3/8" F-NPT

MIN. REQ'D
HEIGHT

[1605]
63 1/4"

[273]
10 3/4"

[541]
21 1/4"

[283]
11 1/8"

GENERAL SPECIFICATIONS:

- DRY WEIGHT = 95 LBS. (APPROXIMATE)
- WET WEIGHT = 125 LBS. (APPROXIMATE, 4 GAL. WATER)
- MAWP = 120 PSIG @ 120°F
- MAWT = 120 °F
- 1HP, 1200 RPM, 230/460 VAC, 3Ø MOTOR
 - 3.8 A / 1.9 A FLA AMPS
- PURGE CHAMBER
 - 2IN PURGE STANDARD (SHOWN)
 - OPTIONS AVAILABLE

MATERIALS:

- SCH80 PVC, ACETAL
- DRIVE TRAIN: 2205SS
- FILTER: 316SS

SCREEN SIZES

- FILTER ELEMENTS AVAILABLE IN 4 STANDARD SIZES
 - 15, 25, 50 & 100µm, OTHER SIZES UPON REQUEST

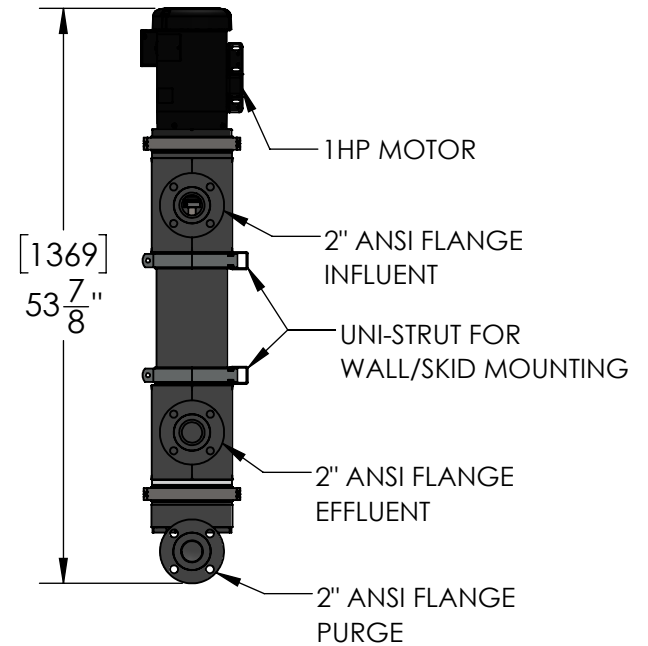

SPIRAL WATER TECHNOLOGIES, INC.



200 POND AVE
MIDDLESEX, NJ 08846
P: 732-629-7553

DRAWN BY KB	10/10/2019
CHECKED BY KB	10/10/2019
APPROVED BY GJL	10/10/2019

TITLE MODEL 850 OEM FILTER	REV F
MODEL CONFIGURATION SWT850-OEM-PVC-EPD-21S-FLN-10H-MTF	

PRODUCT SPECIFICATION DRAWING

SCALE 1:18	WEIGHT 95 LBS	SHEET 1 OF 1
---------------	------------------	--------------