

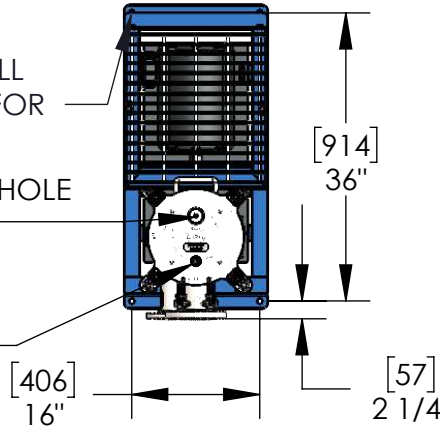

4X ϕ 5/8" THRU ALL MOUNTING HOLES FOR 1/2" BOLTS

1/2"-13 TAPPED HOLE FOR LIFTING

INFLUENT AIR RELEASE 1/2" NPT



GENERAL SPECIFICATIONS:

- DRY WEIGHT = 537 LBS. (APPROXIMATE)
- WET WEIGHT = 621 LBS. (APPROXIMATE, 12 GAL. WATER)
- MAWP = 150 PSIG @ 190°F
- MAWT = 190 °F
- 1:1.5 GEARBOX
- 5HP, 1200 RPM, 230/460 VAC, ϕ 3 MOTOR
 - 13.8 A / 6.9 A FLA AMPS

MATERIALS:

- FDA APPROVED MATERIALS
- FRAME: POWDER COATED CARBON STEEL
- HOUSING/ DRIVE TRAIN: 304SS, OTHER
- FILTER ELEMENT: 316SS
- SILICON-CARBIDE MECHANICAL SEAL

SCREEN SIZES:

- SPECIFY 15,25,50 OR 100 μ m, OTHER SIZES UPON SPECIAL REQUEST

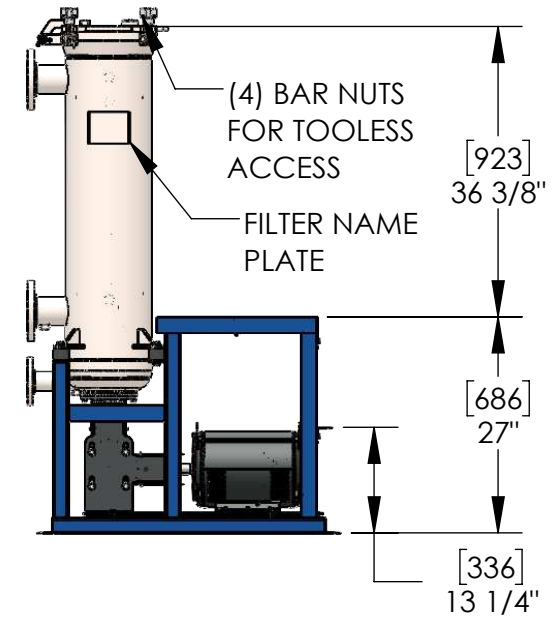
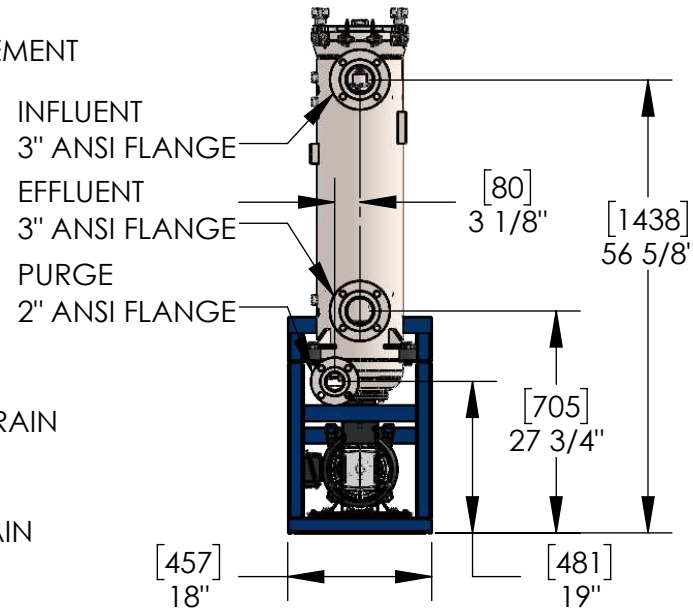
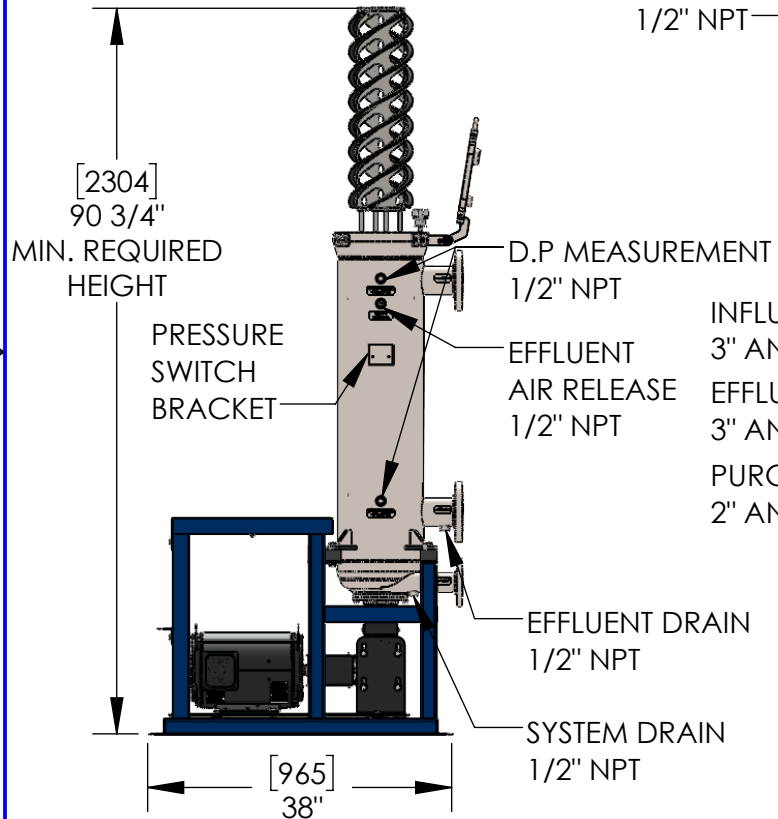

SPIRAL WATER TECHNOLOGIES, INC.



200 POND AVE
MIDDLESEX, NJ 08846
P: 732-629-7553

DRAWN BY	MC	6/20/2019
CHECKED BY	DL	6/21/2019
APPROVED BY	GJL	6/21/2019

TITLE		T1000 OEM FILTER ASSEMBLY
MODEL CONFIGURATION		
T1000-OEM-304-EPD-21S-TPC-50H-MTF		REV F

PRODUCT SPECIFICATION DRAWING

SCALE	1:24	WEIGHT	537 LBS	SHEET 1 OF 1
-------	------	--------	---------	--------------