

T1000-QPX

Quadplex Model T1000 Filter System

LIQUID/SOLID SEPARATOR FILTER

V 2.2

PRODUCT DESCRIPTION

The T1000-QPX is a liquid/solid separator and automatic self-cleaning filter system designed to remove Ultra High and Variable Total Suspended Solids (TSS) from a fluid stream. Each filter unit contains a motor-driven, spiral-shaped brush that continuously cleans collected debris from inside the filter element. Solids collect at the bottom of the filter housing to be expelled through an automatic purge valve or a continuous concentrate stream. The system does not require high pressures to operate and performs at very low differential pressure. No backwash, cross flow or booster pumps required.

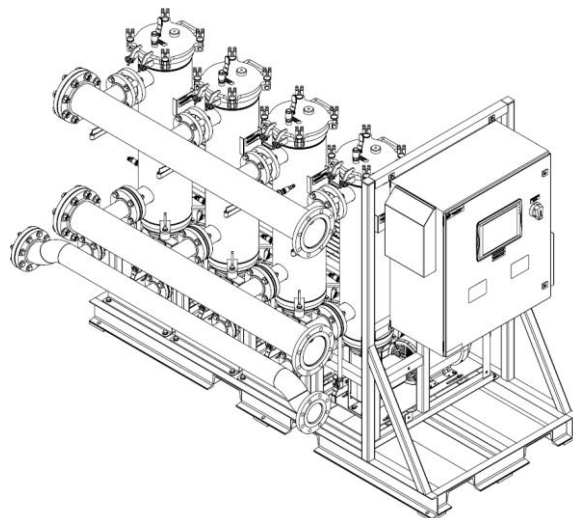

APPLICATIONS

Protection of Monitoring Equipment, Nozzle Protection, Bearing and Seal Protection, Wastewater, Recycled Water, TSS and BOD Reduction, River water Cooling Filtration

TECHNICAL SPECIFICATION

Inlet:	6" Class 150 ANSI Flange
Filtered Outlet:	6" Class 150 ANSI Flange
Purge Outlet:	4" Class 150 ANSI Flange
Max Flow:	4360 m ³ /day (800 gpm)
Filtration Rating:	15 - 100 micron
Max TSS:	15,000 ppm
Max Operating Press:	10.3 bar (150 psi) @70°F
Min Operating Press:	0.69 bar (10 psi)
Max Temp:	90°C (190°F)
Head Loss:	<0.1 bar (2 psi)
Power Requirement:	3-Ph, 230, 120A (460VAC optional)
Purge Valve:	2" Pneumatic Pinch Valve
Air Requirement:	30 psi above media pressure
Max Air Pressure:	120 psi

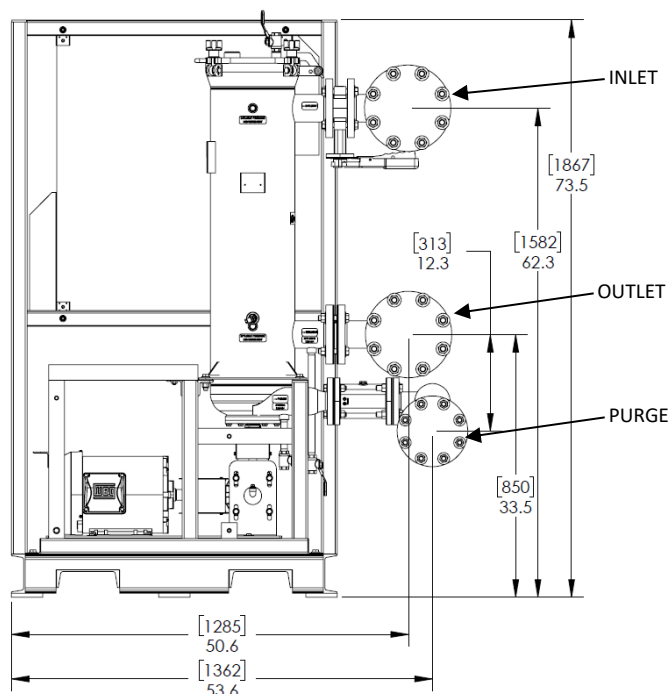

MATERIALS OF CONSTRUCTION

Wetted Components: 304 SS, 316SS, Nylon 6.12
Elastomers: Buna-N, EPDM or Viton
Filter Elements: 316 SS

PERFORMANCE SPECIFICATION

The spiral shaped brush is designed to rotate continuously, so there is always less than 1 psi head loss across the filter screen. Flow through the filter unit is limited by both solids loading and hydraulic loading on the screen. Flow rates listed below assume a viscosity of 1.0 cP and TSS up to 1000 mg/l. The control system will monitor the solids build up in the housing and open the purge valve when necessary. The unit will include a 5 psi cracking pressure check valve on the filtered outlet and a pinch valve on the purge outlet. Operating pressure in the 5 to 20 psi range is optimal, though the unit is capable of operating at 150 psi.



Brush

Flow Rates for TSS up to 1000 ppm

Filter Screen	Nominal Filtration Rating (microns)	Max Flow Rate (gpm, [m ³ /hr])
SWT1000-FE-BB	15	400 [90.8]
SWT1000-FE-GG	20	532 [120.8]
SWT1000-FE-YY	25	660 [149.9]
SWT1000-FE-RR	50	800 [181.7]

Note: The higher the solids, the higher the perceived apparent viscosity. At TSS above 1000 ppm, lower flow rates are required to avoid fouling of the filter screen.



Filter Screen